

The **Universal Low Pressure (U3, UR)** check valve is a one piece body machined from bar stock and is designed for minimum pressure drop. The valve has a light-weight, compact design that provides maintenance-free, dependable service. NPT threads are per ASME B1.20.1. Also available with ISO 7 "Rp" threads. (UR). These valves can also be used as a low pressure relief valve or vacuum breaker by using the desired spring settings.

NOTE: Many valves in this series can be supplied with B16.34 certification. Consult the factory for more information.

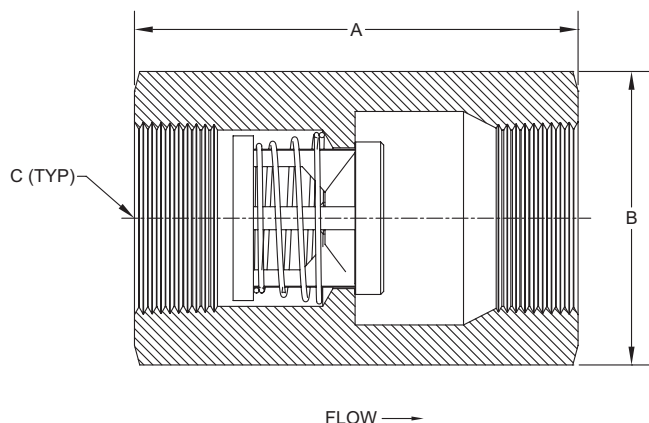

Nom. Pipe Size	Size Code	A	Hex ¹ Size B	C	Orifice Diameter
3/8	C	2.16	13/16	3/8 NPT	0.348
1/2	D	2.71	1-1/8	1/2 NPT	0.464
3/4	F	2.95	1-1/4	3/4 NPT	0.593
1	H	3.64	1-5/8	1 NPT	0.890
1-1/4	I	3.91	2-1/4	1-1/4 NPT	1.135
1-1/2	J	4.36	2-1/2	1-1/2 NPT	1.385
2	K	5.85	3	2 NPT	1.555
2-1/2	L	5.50	3-3/4	2-1/2 NPT	1.555
3	M	6.25	4-1/2	3 NPT	2.025
4	N	7.13	5-1/2	4 NPT	2.560

¹ May be larger and/or round.

Body Material ²	Availability	Non-Shock Pressure-Temp. Rating @ 100° F Consult factory for P-T rating above 100° F	
316 Stainless Steel (SS)	Standard	3/8" - 3"	4"
Carbon Steel (CS)			
Brass (BR)			
Alloy 20 (A2)	Semi-standard	3000 PSIG (1500 PSIG for o-ring seats)	1500 PSIG
Alloy C-276 (HC)			
MONEL® 400 or Alloy R405	Contact the factory for these or other materials		
Alloy B (HB)			
Titanium (TI)			

² See page 56 for material grade information.

**Universal Low Pressure
For Water at 72°F**

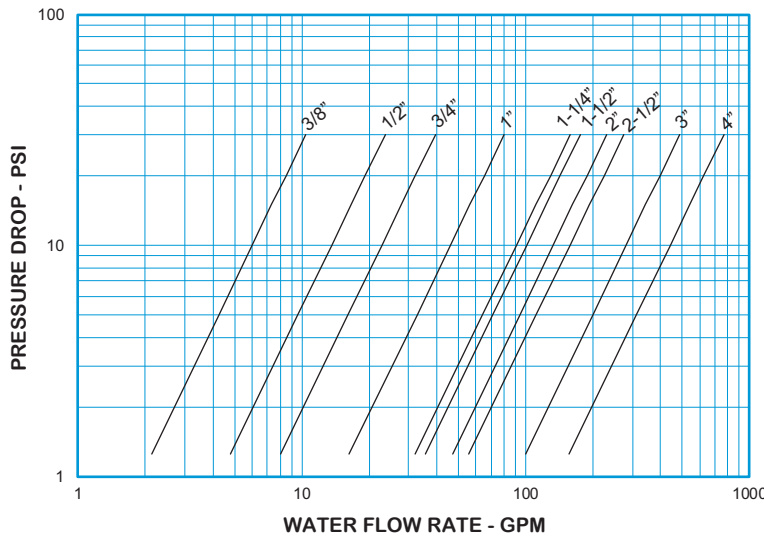

Note: All flow curves and Cv values presume the valves are fully open with 1/2 PSI cracking pressure springs. Consult the factory for more information.

STYLE U3 C _v VALUES & VALVE WEIGHTS			
C _v	SIZE	SS & CS ALLOYS	BRASS
1.9	3/8	3.0 oz.	3.3 oz.
4.3	1/2	8.5 oz.	9.1 oz.
7.2	3/4	9.6 oz.	10.1 oz.
14.6	1	1.2 lb.	1.3 lb.
28.8	1-1/4	2.9 lb.	3.2 lb.
31.9	1-1/2	3.6 lb.	3.9 lb.
42.0	2	6.5 lb.	7.2 lb.
50.0	2-1/2	9.2 lb.	10 lb.
89.0	3	14.3 lb.	15.5 lb.
140	4	21.7 lb.	23.9 lb.

See page 51 for Flow Formulae.
Valve weights are approximate.

**HOW TO ORDER
CHECK-ALL STYLE U3**

BODY MATERIAL

ALLOY 20 = A2
BRASS = BR
CARBON STEEL = CS
ALLOY B = HB
ALLOY C-276 = HC
MONEL® 400 OR ALLOY R405 = MO
316 SS = SS
TITANIUM = TI

See p. 3 for temperature ratings

SPRING CRACKING PRESSURES (PSI)

Must use decimal as a character unless selecting NO SPRING. Specify Exact Setting

SPRING RANGES	EXAMPLE
.000 TO .999	= .500
1.00 TO 9.99	= 1.50
10.0 TO 85.0	= 15.0
NO SPRING	= NOSPRG

STANDARD CRACKING PRESSURES ①

.125	.500	1.50	3.50
------	------	------	------

(Sizes C-I Only)

Note: Many other cracking pressures are available. All spring tolerances +/- 15%.

U

VALVE STYLE

NPT Threads = U3
ISO 7 Rp Threads = UR

SIZE

3/8 = C
1/2 = D
3/4 = F
1 = H
1-1/4 = I
1-1/2 = J
2 = K
2-1/2 = L
3 = M
4 = N

SEAT MATERIAL ②

AFLAS® = AS
BUNA-N = BN
EPDM ③ = EP
KALREZ® = KZ
"METAL-TO-METAL" = MT
NEOPRENE = NE
PTFE = TF
VITON™ = VT

See p. 3 for temperature ratings

SPRING MATERIAL

316 SS = SS
ALLOY C-276 = HC
ALLOY B = HB
INCONEL® X750 OR ALLOY X750 = IX
MONEL® 400 = MO
17-7PH SS = PH
TITANIUM = TI

See p. 4 for temperature ratings

SPECIAL OPTIONS

T = FEP ENCAPSULATED SPRING
Contact the factory for more options

See p. 4 for temperature rating

Listed above are the most common material selections. Please contact the factory for additional options.

① .500 PSI is the only standard cracking pressure for spring materials other than Stainless Steel. .125 PSI springs are not recommended for installations with flow vertical down.

② Seat materials other than "metal-to-metal" have a maximum pressure rating of 1500 PSI. "Metal-to-Metal" and PTFE seats are not resilient. See page 52 for allowable leakage rates.

③ EP seats not recommended for use with Carbon Steel valves.