

Valve shown in ferrules.  
Ferrules and clamp not included.



The **Sanitary Cartridge (SC)** valve is a stainless steel check valve for use with new or existing sanitary ferrules. The SC design seals on the ID of ferrules with replaceable food grade seals (Standard is FDA EPDM). Designed for use with sanitary quick clamp fittings as manufactured by Alfa Laval Inc., Cherry-Burrell S-Line, or other identically dimensioned sanitary fittings (ferrules not included). The compact SC design fits inside a single fitting and requires no additional space in the line. Its size makes it extremely economical when compared to full-bodied valves. For applications requiring a 3-A compliant valve and/or 32 RA or finer surface finishes, see our 3S series on page 23.

The SC valve can also be used as a low pressure relief valve or vacuum breaker by using the desired spring settings.

**Note: USP Class VI o-rings can be supplied with certification.**

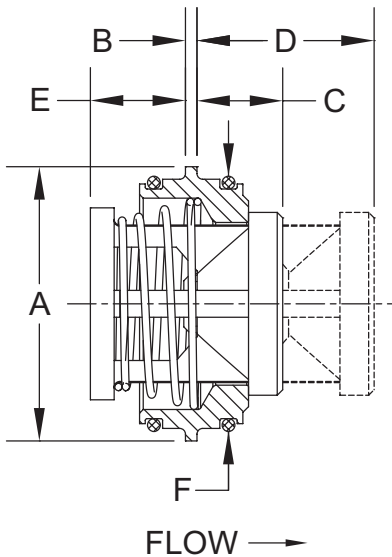

Line Size	Size Code	A	B	C ❶	D ❷	E	F ❸	Orifice Diameter
3/4	F	3/4	1/16	0.44	0.78	0.28	0.620	0.348
1	H	1	1/16	0.53	0.89	0.30	0.870	0.464
1-1/2	J	1-1/2	1/16	0.53	1.06	0.63	1.370	0.890
2	K	2	1/16	0.66	1.39	0.66	1.870	1.135
2-1/2	L	2-1/2	1/16	0.69	1.56	0.88	2.370	1.385
3	M	3	1/16	0.75	1.97	1.25	2.870	2.025
4	N	4	1/16	0.88	2.41	1.63	3.834	2.560

- ❶ Maximum nominal dimension for valve closed.
- ❷ Maximum nominal dimension for a fully open valve with no spring.
- ❸ Valves are designed to function with fittings having these internal diameters. ( $\pm 0.005$ )

Body Material ❹	Line Size	Non-Shock Pressure-Temp Rating @ 100°F Consult factory for P-T ratings above 100°F
316/316L Stainless Steel (SS)	3/4" - 1-1/2"	1000 PSIG
	2" - 4"	725 PSIG

❹ See page 56 for material grade information.

**Sanitary Cartridge Valve**  
For Water at 72°F

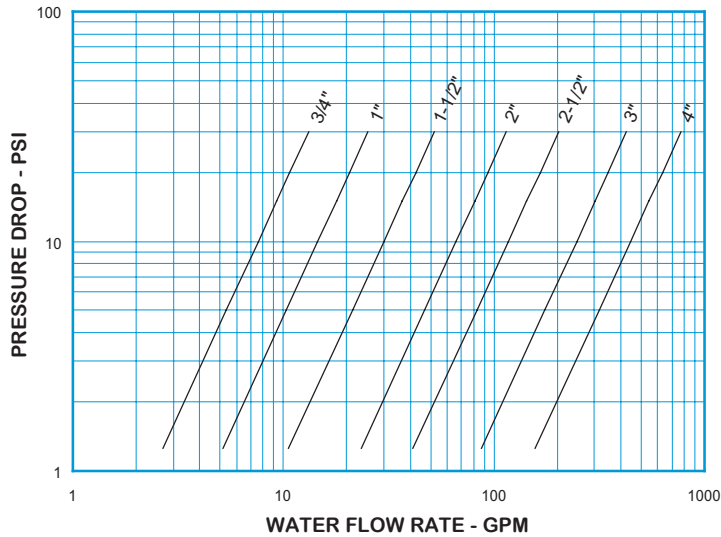

**Note:** All flow curves and Cv values presume the valves are fully open with 1/2 PSI cracking pressure springs. Consult the factory for more information.

STYLE SC C <sub>v</sub> VALUES & VALVE WEIGHTS		
C <sub>v</sub>	SIZE	316SS
2.4	3/4	0.3 oz.
4.6	1	1.0 oz.
9.5	1-1/2	2.9 oz.
20.9	2	6.1 oz.
37.0	2-1/2	11.2 oz.
77.9	3	11.4 oz.
141	4	2.6 lb.

See page 51 for Flow Formulae.  
Valve weights are approximate.

**HOW TO ORDER  
CHECK-ALL STYLE SC**

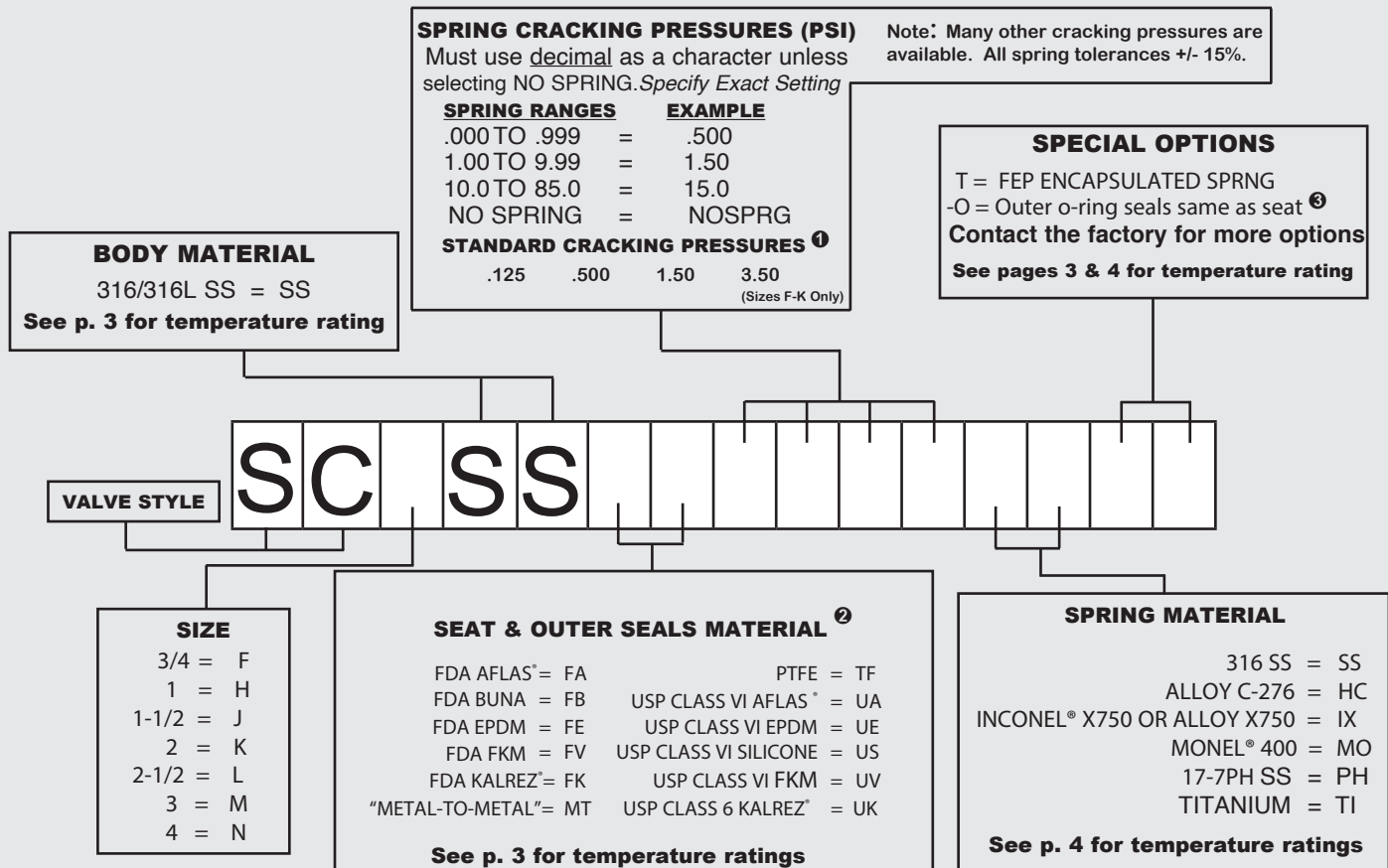

Listed above are the most common material selections. Please contact the factory for additional options.

- ① .500 PSI is the only standard cracking pressure for spring materials other than Stainless Steel. .125 PSI springs are not recommended for installations with flow vertical down.
- ② "Metal-to-Metal" and PTFE seats are not resilient nor available for outer seals. See page 52 for allowable leakage rates.
- ③ -O option not available for "Metal-to-Metal" and PTFE seats, FE will be used as standard. Consult factory for other options.